



# BUILDING AND DEVELOPMENT APPLICATION

APPLICANT CONTRACT INFORMATION		
Name:		
Mailing Address:		Postal Code:
Phone:	Cell:	Home:
Email:		

BUILDER CONTACT INFORMATION		
Name:		
Mailing Address:		Postal Code:
Phone:	Cell:	Home:
Email:		

TYPE OF DEVELOPMENT	
<input type="checkbox"/> Residential	<input type="checkbox"/> Commercial

PROPERTY INFORMATION
Property Civic Address:
Property Owner (if different from applicant):

PURPOSE OF APPLICATION		
<input type="checkbox"/> Single Dwelling	<input type="checkbox"/> Commercial Building	<input type="checkbox"/> Deck/Patio
<input type="checkbox"/> Single Dwelling with Apartment	<input type="checkbox"/> Commercial Shed/Garage	<input type="checkbox"/> Change of Use
<input type="checkbox"/> Double Dwelling	<input type="checkbox"/> Commercial Extension	<input type="checkbox"/> Fence
<input type="checkbox"/> Dwelling Extension	<input type="checkbox"/> Demolition/Removal	<input type="checkbox"/> Pool/Hot tub
<input type="checkbox"/> Shed/Garage	<input type="checkbox"/> Driveway/Paving	<input type="checkbox"/> Other
Comments:		

MEANS OF SERVICING	
<input type="checkbox"/> Municipal Water	<input type="checkbox"/> Septic System
<input type="checkbox"/> Municipal Sewer	<input type="checkbox"/> Other (please specify):
<input type="checkbox"/> Drilled/Surface Well	

PROPOSED MEANS OF PROPERTY ACCESS
<input type="checkbox"/> New Driveway (Length _____ m)
<input type="checkbox"/> Existing Driveway (Length _____ m)

BUILDING SIZE				
	Total Floor Area	Height	Lot Frontage	Lot Area
Building (including attached garage):	f <sup>2</sup>	F	F	f <sup>2</sup>
Shed/Garage:	f <sup>2</sup>	F	F	f <sup>2</sup>
Building Extension:	f <sup>2</sup>	F	F	f <sup>2</sup>
Other	f <sup>2</sup>	F	F	f <sup>2</sup>
Estimated Value of Construction: \$				

SERVICE NL APPROVAL LETTER ATTACHED (Commercial Only)	
<input type="checkbox"/> Yes	<input type="checkbox"/> NO

PROPERTY FOR RENTAL INCOME	
<input type="checkbox"/> Yes	<input type="checkbox"/> NO

## Plot Plan

- Indicate the proposed location of the new Building in relation to the Lot Lines.
- Indicate the location of Accessory Buildings, Fences, and extensions in relation to the Existing Building and the Lot Lines.
- Indicate the distance between the Accessory Building and the Existing Building.
- Indicate Driveway Location.

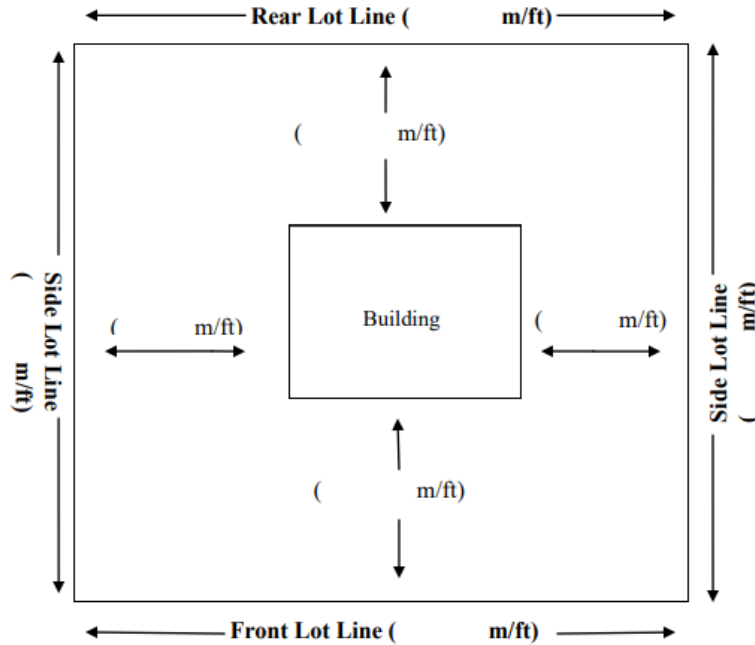

### DECLARATION STATEMENT:

I herby submit this application and confirm that the information supplied is correct to the best of my knowledge. I agree to comply with all Town Regulations, agree to develop in accordance with the plans approved by the Town of Springdale, and not to commence development without applicable written approval and/or permit from the Town. I understand that the responsibility to meet the National Building Code and Fire Code requirements and/or any other Government requirement is placed with, and is, the responsibility of the original applicant or owner or permit holder or any subsequent purchaser of the subject property. I understand that the Town of Springdale does not necessarily have fully and up to date information respecting the subject property.

\_\_\_\_\_

Applicants Signature

\_\_\_\_\_

Date

\_\_\_\_\_

Property Owner's Signature

\_\_\_\_\_

Date

**NOTE:** Where the applicant and the property owner are not the same, the signature of the property owner is required before the application can be accepted for processing.

The following documents are required before the application can be accepted for processing:

- Completed application form
- Legal property survey or equivalent
- Plot Plan
- Building Plans

### FOR OFFICE USE ONLY

#### Checklist

Plot Plan	Date Received _____
Survey	Date Received _____
Building Plans	Date Received _____

Approved by \_\_\_\_\_

Permit # \_\_\_\_\_